

# LWR-K VERSION - 2800 RPM

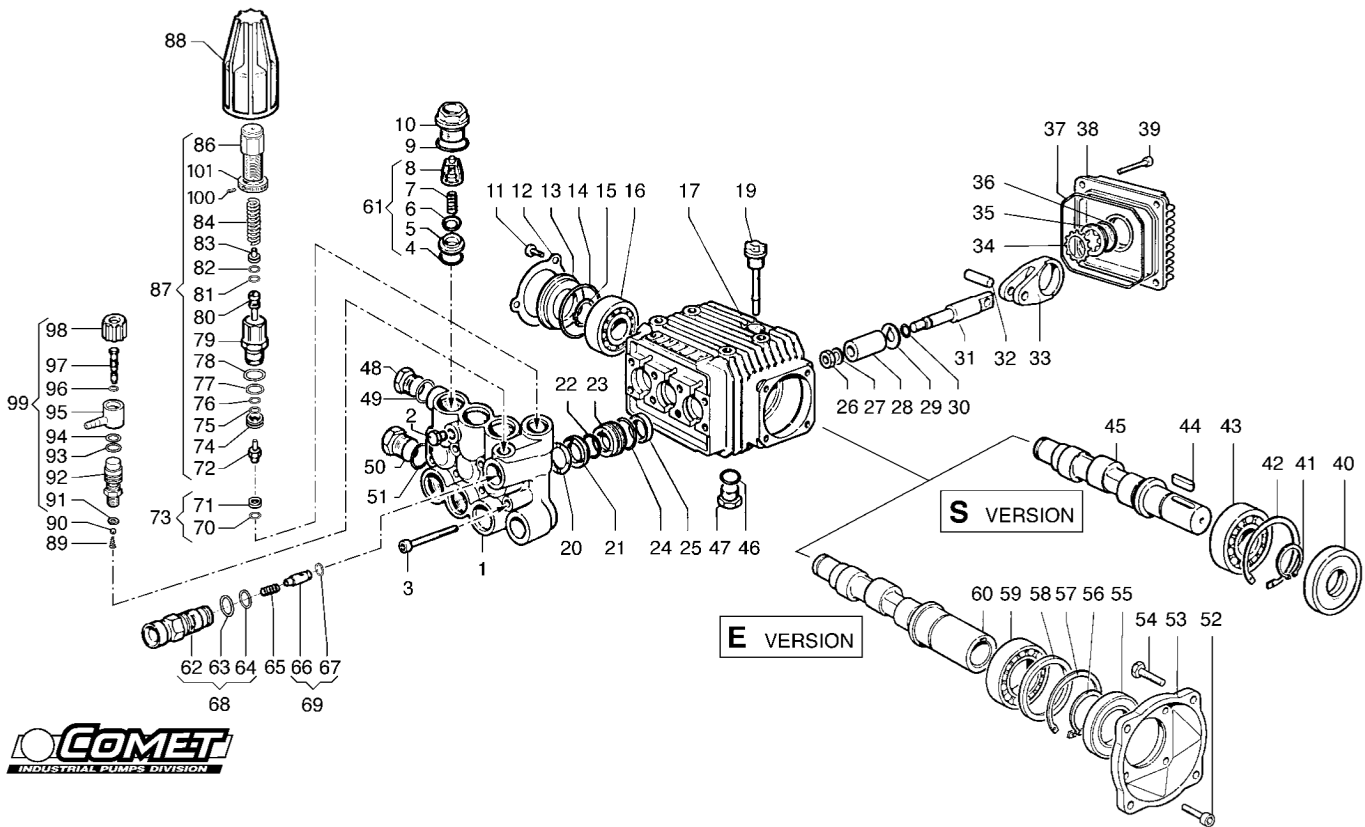

ITEM	PART No.	KIT	DESCRIPTION	Qty.	MODELS
1	3218.0112.00		MANIFOLD Ø 15 mm	1	
2	3202.0018.00		CAP G1/8	1	
3	3609.0108.00		SCREW M6X55	1	2020 S - 3016 S 3016 E - 3020 S 3517 S
	3609.0152.00		SCREW M6X55	8	3025 S - 3525 S 4022 S
4	1210.0046.00	A-D	O-RING 2,62X 17,13 mm	6	
5	3009.0087.00	A	VALVE SEAT	6	
6	3604.0017.00	A	VALVE PLATE	6	
7	1802.0177.00	A	SPRING	6	
8	1205.0025.00	A	VALVE GUIDE	6	
9	1210.0048.00	A-D	O-RING 2,62X 20,24 mm	6	
10	3202.0155.00		CAP	6	
11	3609.0088.00		SCREW M5X10	3	
12	1004.0012.00		CRANKCASE COVER	1	
13	0402.0172.00		SPACER	1	
14	1210.0386.00	D	O-RING 3,53X44,04 mm	1	
15	3019.0011.00		SNAP RING	1	
16	0438.0066.00		BALL BEARING 20X52X15 mm	1	2020 S - 3016 S 3016 E - 3020 S 3517 S
	0438.0069.00		BALL BEARING 20X52X15 mm	1	3025 S - 3525 S 4022 S
17	0403.0128.00		CRANKCASE	1	
19	3200.0051.00		OIL DIPSTICK	1	
20	0009.0196.00	B	HEAD RING Ø15 mm	3	
21	1241.0034.00	B	PACKING Ø 15 mm	3	
22	1241.0030.00	B	PACKING 15X22X5,5 mm	3	
23	0009.0198.00		PACKING RETAINER Ø15 mm	3	
24	1210.0223.00	B-D	O-RING 1,78X26,7 mm	3	
25	0019.0095.00	D	OIL SEAL 15X24X5 mm	3	
26	0600.0048.00	C	NUT	3	
27	2811.0080.00	C	WASHER 8,2X14X1,5 mm	3	
28	0202.0020.00	C	PISTON Ø15 mm	3	
29	2812.0038.00	C	WASHER	3	
30	1210.0055.00	C-D	O-RING 1,78X 6,07 mm	3	
31	2409.0044.00		PISTON GUIDES	3	
32	3011.0014.00		WRIST. PIN	3	

ITEM	PART No.	KIT	DESCRIPTION	Qty.	MODELS
33	0205.0048.00		CON. ROD	3	3016 S - 3016 E 3517 S
	0205.0050.00		CON. ROD	3	2020 S - 3020 S 3025 S - 3525 S 4022 S
34	3019.0033.00		SNAP RING Ø18 mm	1	
35	3201.0010.00		OIL INDICATOR	1	
36	1210.0333.00	D	O-RING 1,78X23,52 mm	1	
37	1210.0206.00	D	O-RING 2,62X101,27 mm	1	
38	0402.0142.00		CRANKCASE COVER	1	
39	3609.0041.00		SCREW M6X25	4	
46	1210.0441.00	D	O-RING 2X14 mm	1	
47	3200.0007.00		CAP 3/8GAS OT58	1	
48	3200.0007.00		CAP 3/8GAS OT58	1	
49	2811.0084.00		WASHER 16,7X22X1,5 mm	1	
50	3202.0015.00		CAP G1/2	1	
51	2811.0086.00		WASHER 21,2X27X1,5 mm	1	
61	1220.0030.00		VALVE ASS. BLY.	6	
	3410.0290.00	E	INJECTOR BODY M22x1,5	1	
	3410.0288.00	E	INJECTOR BODY 3/8" NPT	1	
63	1210.0398.00	E-F	O-RING	1	
64	1210.0402.00	E-F	O-RING	1	
65	1802.0179.00	E	SPRING	1	
66	2409.0076.00	E	CHECK VALVE	1	
67	1210.0397.00	E-F	O-RING	1	
68	3410.0289.00		INJECTOR BODY KIT M22x1,5	1	
	3410.0287.00		INJECTOR BODY KIT 3/8" NPT	1	
69	2409.0075.00		CHECK VALVE KIT	1	
70	1210.0403.00	E-F	O-RING 1,78X8,73 mm VT	1	
71	3009.0122.00	E-F	VALVE SEAT	1	
72	3002.0508.00	E-F	HOUSING WITH BALL	1	
73	3009.0013.00		SEAT KIT	1	
74	0009.0204.00	E-F	RING	1	
75	0009.0205.00	E-F	BACK RING	1	
76	1210.0405.00	E-F	O-RING	1	
77	1210.0404.00	E-F	O-RING	1	
78	1210.0407.00	E-F	O-RING	1	
79	0204.0045.00	E	HOUSING	1	
80	2409.0077.00	E-F	PISTON ROD	1	
81	1210.0406.00	E-F	O-RING	1	